

RDHS-01 密闭取样器

Sampler

概述

RDHS-01密闭取样器适用于船舶舱、柜及其他液柜中分层清晰且存在多种非腐蚀性液体介质的取样。

技术参数

- ✦ 型式: 便携式
- ✦ 卷尺规格: 公制
- ✦ 卷尺长度: 15m, 30m
- ✦ 最小分度值: 1mm
- ✦ 取样介质液位高度: $\geq 100\text{mm}$
- ✦ 取样介质密度范围: $0.6\sim 3.5\text{g}/\text{cm}^3$
- ✦ 介质温度范围: $-25\sim 110^\circ\text{C}$
- ✦ 外形尺寸: $1150\times 270\times 180\text{mm}$



Summary

RDHS-01 Sampler is suitable in ships cabin/cabinet and liquid which is delaminating expressly and existing many non-corrosive liquid medium in other TANK System

Tech. Spec.

- ✦ Type: Portable
- ✦ Tape: Metric
- ✦ Tape length: 15m, 30m
- ✦ Min division value: 1mm
- ✦ Medium height: $\geq 100\text{mm}$
- ✦ Medium density: $0.6\sim 3.5\text{g}/\text{cm}^3$
- ✦ Medium temperature: $-25\sim 110^\circ\text{C}$
- ✦ Outline size: $1150\times 270\times 180\text{mm}$

CDV-2 甲板阀/Deck Valve

适用范围

CDV型甲板阀是油水界面探测器及密闭取样器的专用配套设备, 主要用于油轮及化学品运输船, 也可用于石油化工行业及海洋石油钻井平台上使用。

结构

- ✦ 第一部分: 甲板阀的盖子, 不用时旋紧, 以防灰等进入阀体
- ✦ 第二部分: 用于与UIT油水界面探测器匹配的1" 快速接口
- ✦ 第三部分: 用于与RDHS-01密闭取样器匹配的2" 快速接口
- ✦ 第四部分: 内径是 $\Phi 48$ 的球阀
- ✦ 第五部分: 甲板安装法兰

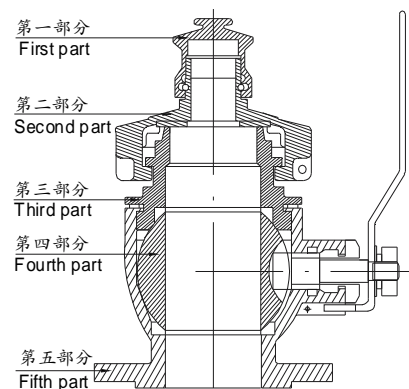

Application

CDV Deck valve is matched with Oil/water interface detector and Sampler. It is mainly used in oil tanker, chemical tanker, petrochemical industry and marine oil platform.

Struction

- ✦ First part: deck cover. Roll tightly when not in use.
- ✦ Second part: 1" Quick connector for UIT oil/water interface detector
- ✦ Third part: 2" Quick connector for RDHS-01 sampler
- ✦ Forth part: $\Phi 48$ Ball valve
- ✦ Fifth part: Deck installation flange

