

CP-2GM Constant Pressure Calibration Cylinder

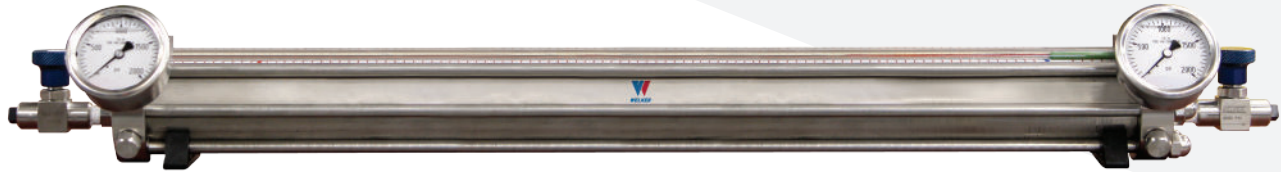

The Welker® CP-2GM Constant Pressure Calibration Cylinder is the most effective solution for containing and maintaining calibration standards. Our cylinder provides safety, reliability, and convenience to calibration standards used in laboratories world wide.

Features

- Proven safety in cylinder design
- Maintains the integrity of the calibration standard
- Internal Gravity Mixer™
- Visual capacity magnetic indicator
- DOT and Transport Canada* approved for transportation
- Manufactured with over 40 years of industry-leading expertise and design

Benefits

- Provides maximum degree of confidence in the integrity of the calibration standard
- Utilizes complete volume of the standard before returning to the calibration standard manufacturer
- Internal Gravity Mixer™ provides a proper sample mix for accurate lab analysis
- Easy to handle
- Requires minimal storage space in laboratory
- Compact design makes shipping cost-effective



Transport*
Canada

SPECIFICATIONS

CP-2GM CONSTANT PRESSURE CALIBRATION CYLINDER

CP-2GM

Materials of Construction	316/316L Stainless Steel
Seal Material Options	Kalrez® Viton®
Sample Inlet Connections	1/4" FNPT
Sample Outlet Connections	1/4" FNPT
Cylinder Volume	1000 cc
Cylinder Mixer Type	Gravity Mixer™
Cylinder Accessories	Rupture Disc, Reliefs, Valves, and Gauges
Operating Pressure	1800 psig MAOP @ -20 °F to 120 °F
Transport Approvals	DOT-SP 7657 Transport Canada SU 4781*
Industry Standards	Complies with API 8.1, API 14.1, ASTM D1265, ASTM D3700, ASTM D4057, GPA 2166, GPA 2174, ISO 3170, ISO 4257, and ISO 10715

* Available upon request.

STANDARD OPTIONS

CP-2GM CONSTANT PRESSURE CALIBRATION CYLINDER

SEALS

C2SI110

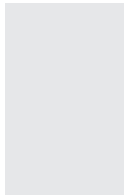

AA0B0A00A0

A or F

SEALS

A: Viton®

F: Kalrez® (Product Side) and Viton® (Pre-charge Side)

For custom options, choose **Plus Welker™**.



Customer Inspired. Welker Manufactured.

Collaborate with us to create a custom product unique to your application.

DIMENSIONS

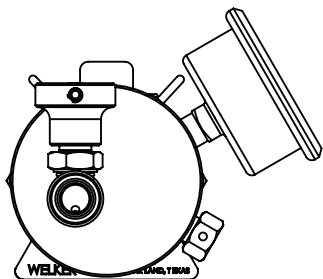
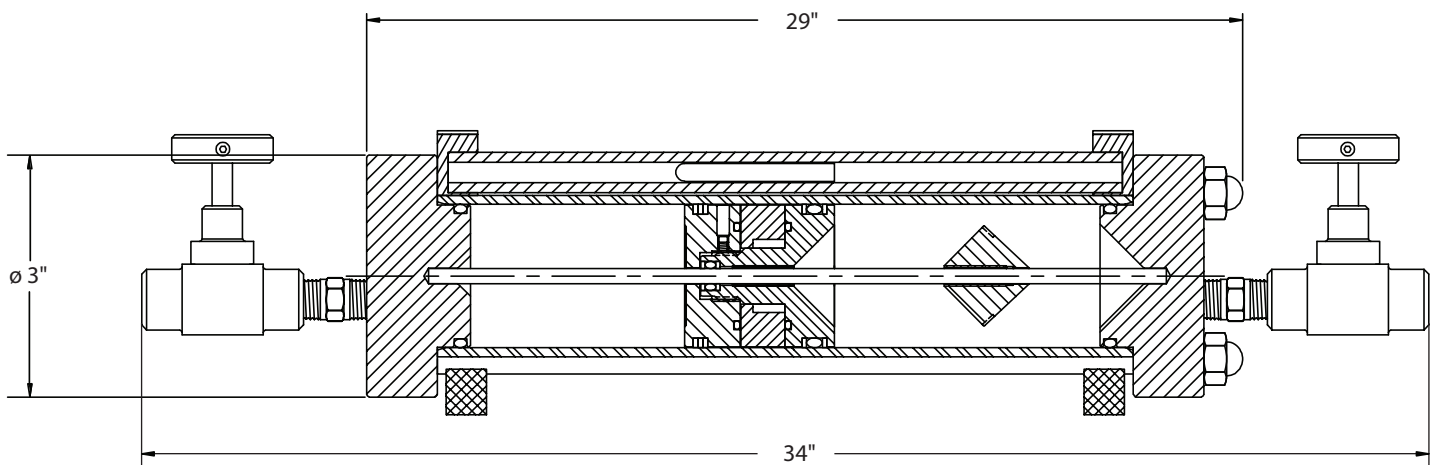

Weight: 17.5 lb empty

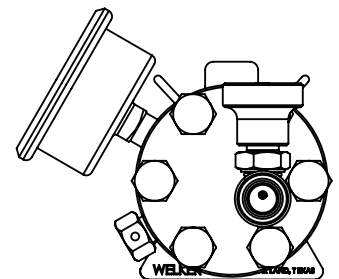

Weight and/or dimensions are approximate.
Specifications subject to change without notice.



13839 WEST BELLFORT STREET SUGAR LAND, TEXAS 77498 | 281.491.2331 | sales@welker.com | WELKER.COM
©2016 Welker, Inc., All Rights Reserved. Welker®, W Welker®, W Logo, WelkerScope®, Welker Jet®, and OdorEyes® are registered trademarks owned by Welker, Inc.